

Control units

Installation and operating instructions
series: Megacontrol II

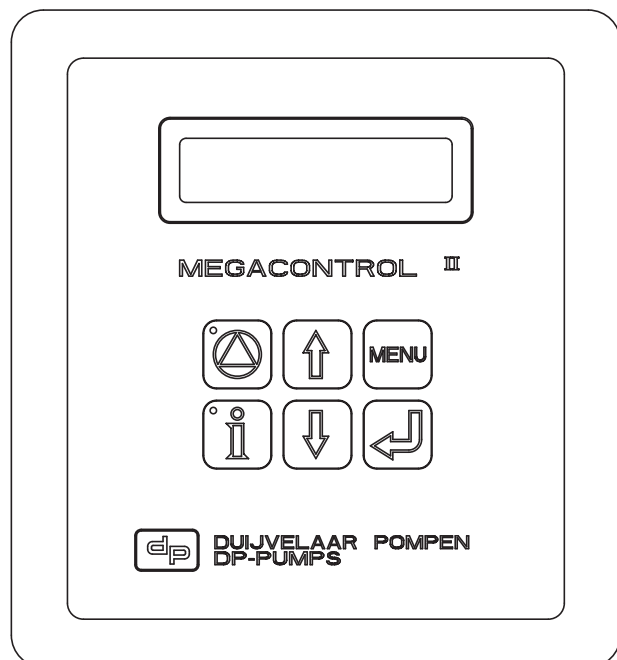

Table of Contents

1	Introduction	
1.1	Preface.....	3
1.2	Icons and symbols	3
2	Identification, service and technical support	
2.1	Identification, service and technical support	4
2.2	Supplementary documentation	4
3	Warranty	
3.1	Terms of warranty	5
4	Safety and environment	
4.1	General	6
4.2	Users.....	6
4.3	Safety provisions.....	6
4.4	Safety precautions	7
4.5	Environmental aspects.....	7
5	Introduction	
5.1	General	8
5.2	Intended use	8
5.3	Working range.....	8
5.4	Operation	8
6	Transport	
6.1	Transport and storage.....	10
7	Install	
7.1	Mechanical install.....	11
7.2	Electrical install	11
7.3	Commissioning	11
8	Operation	
8.1	Display	12
8.2	Retrieve pump information	12
8.3	Show failure messages	13
8.4	Read/set parameters	13
9	Annexes	
9.1	Megacontrol II	14
9.2	Build-in diagram	15
9.3	Electrical connections	16
9.4	Parameter list.....	17
9.5	Failure messages.....	28
9.6	Factory settings.....	29
9.7	Declaration of conformity (IIB)	33

1 Introduction

1.1 Preface

The manual contains important information for reliable, proper and efficient operation. Compliance with the operating instructions is of vital importance to ensure reliability and a long service life of the product and to avoid any risks.

The first chapters contain information about this manual and safety in general. The following chapters provide information about normal use, installation, maintenance and repairs of the product. The annexes contain the technical data, the parts drawings and the declaration(s) of conformity.

- Make yourself familiar with the content.
- Accurately follow the directions and instructions.
- Never change the sequence of the operations to be carried out.
- Keep this manual or a copy of it together with the logbook in fixed place near the product, which can be accessed by all personnel.

1.2 Icons and symbols

In this manual and in all accompanying documentation the following icons and symbols are used.



WARNING

Danger of electric tension. Safety sign according to IEC 417 - 5036



WARNING

Operations or procedures, if carried out without caution, may cause personal injury or damage to the product. General hazard sign according to ISO 7000-0434



ATTENTION

Is used to introduce safety instructions whose non-observance may lead to damage to the product and its functions.



ENVIRONMENTAL INSTRUCTION

Remarks with respect to the environment.

2 Identification, service and technical support

2.1 Identification, service and technical support

The system is identified based on the text "Megacontrol II" as given on the front of the system.

Indication	Meaning
Megacontrol II	Type of control unit

The following address data are available for service and technical support:

DP-Pumps Kalkovenweg 13 2401 LJ Alphen a/d Rijn The Netherlands	Tel: +31 172 488325 Fax: +31 172 468930 Internet: www.dp-pumps.com E-mail: dp@dp-pumps.com
--	--

2.2 Supplementary documentation

As well as this manual, the documentation given below is also available:

Document	Date/version	Code
General terms of delivery	10-1998	119 / 1998
Documentation	03-2003	97013511

Also see: www.dp-pumps.com

3 Warranty

3.1 Terms of warranty

The warranty period is settled by terms of your contract or at least by the general terms and conditions of sales.



ATTENTION

Modifications or alterations of the product supplied are only permitted after consultation with the manufacturer. Original spare parts and accessories authorized by the manufacturer ensure safety. The use of other parts can invalidate any liability of the manufacturer for consequential damage.



ATTENTION

The warranty relating to the operating reliability and safety of the product supplied is only valid if the product is used in accordance with its designated use as described in the following sections of this manual. The limits stated in the data sheet must not be exceeded under any circumstances.

The warranty becomes invalid if one or more of the points below occur.

- The buyer makes modifications himself.
- The buyer carries out repairs himself or has these carried out by a third party.
- The product has been handled or maintained improperly.
- The product has non original DP-Pumps spare parts fitted.

DP-Pumps remedies defects under warranty if the points below are observed.

- Defects are caused by flaws in the design, the materials or the production.
- The defect has been reported within the warranty period.

Other terms of warranty have been included in the general terms of delivery, which are available upon request.

4 Safety and environment

4.1 General

This DP-Pumps product has been developed in accordance with state-of-the-art technology; it is manufactured with utmost care and subject to continuous quality control.

DP-Pumps does not accept any liability for damage and injury caused by not observing the directions and instructions in this manual. This also applies in cases of carelessness during the installation procedure, use and maintenance of the product.

Non-compliance with safety instructions can jeopardize the safety of personnel, the environment and the product itself. Non-compliance with these safety instructions will also lead to forfeiture of any and all rights to claims for damages.

In particular, non-compliance can, for example, result in:

- failure of important pump/system functions,
- failure of prescribed maintenance and servicing practices,
- injury to persons by electrical, mechanical and chemical effects,
- hazard of the environment due to leakage of hazardous substances,
- explosions.

Depending on specific activities, extra safety measures may be required. Contact DP-Pumps if during use a potential danger arises.



ATTENTION

The owner of the product is responsible for compliance with the local safety regulations and internal company guidelines.



ATTENTION

Not only must the general safety instructions laid down in this chapter on "Safety" be complied with, but also the safety instructions outlined under specific headings

4.2 Users

All personnel involved in the operation, maintenance, inspection and installation of the product must be fully qualified to carry out the work involved.

Personnel responsibilities, competence and supervision must be clearly defined by the operator. If the personnel in question is not already in possession of the required know-how, appropriate training and instruction must be provided. If required, the operator may commission the manufacturer / supplier to take care of such training. In addition, the operator is responsible for ensuring that the contents of the operating instructions are fully understood by the responsible personnel.

4.3 Safety provisions

The product has been designed with the greatest possible care. Original parts and accessories meet the safety regulations. Modifications in the construction or the use of non-original parts may lead to a safety risk.



ATTENTION

Make sure that the product operates within its working range. Only then the product performance is guaranteed.

4.3.1 Labels on the product

The icons, warnings and instructions applied to the product are part of the safety provisions. The labels may not be removed or covered. Labels must remain legible during the entire life of the product. Replace immediately damaged labels.

4.4 Safety precautions

4.4.1 During normal use

- Contact the local electricity company for questions about the power supply.
- Shield parts that can become hot in such a way, that direct contact is not possible.
- Always close the switch box.

4.4.2 During installation, maintenance and repair

Only authorised personnel may install, maintain and inspect the system and repair electrical components. Observe the local safety regulations.

4.5 Environmental aspects

4.5.1 General

The products of DP-Pumps are designed to function in an environmentally friendly way during their entire life. Therefore, when applicable, always use biodegradable lubricants for maintenance.



ENVIRONMENTAL INSTRUCTION

Always act according to the laws, by-laws regulations and instructions with respect to health, safety and the environment.

4.5.2 Dismantling

Dismantle the product and dispose of it in an environmentally friendly way. The owner is responsible for this.



ENVIRONMENTAL INSTRUCTION

Ask at the local government about the re-use or the environmentally friendly processing of discarded materials.

5 Introduction

5.1 General

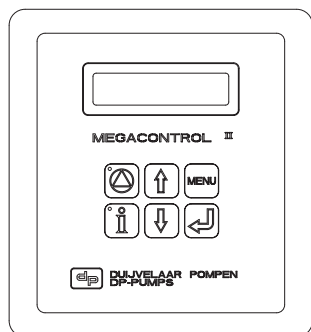

Control units of the type Megacontrol II

Control units of the type Megacontrol II are manufactured by DP-Pumps.

5.2 Intended use

The control unit is suitable for controlling a hydro-unit consisting of 1, 2, 3, 4, 5 or 6 pumps within the indicated working range (see “Working range”).

Any other or further use of the control unit is not in conformity with its intended use. DP-Pumps does not accept any liability for any damage or injury resulting from this. The control unit has been produced in accordance with the current standards and guidelines. Use the control unit exclusively in a perfect technical state, in conformity with the intended use described below.

The *Intended use* as laid down in EN 12100-1 is the use for which the technical product is intended according to the specifications of the manufacturer. The use of the product has been described in the sales brochure and in the user manual. Always observe the instructions given in the user manual. When in doubt the product must be used as becomes evident from its construction, version and function.

5.3 Working range

The working range of the control unit can be summarized as follows:

Table 1: Specification of the working range

Type	Megacontrol II
Maximum ambient temperature [°C]	50
Relative atmospheric humidity [%]	20 - 90 (no condensation)
Voltage [V]	1 x 230 (± 10%)
Frequency [Hz]	50 (+5%/-6%) 60 (+5%/-6%)

Table 2: Specific applications

Type	Application area
Megacontrol II	Building possible in the installations listed below: <ul style="list-style-type: none"> Hydro-unit with 1 - 6 pumps Break unit with 1 - 6 pumps

5.4 Operation

The microprocessor-controlled Megacontrol II is an intelligent control for the different components of pressurization units consisting of six pumps at the most. The Megacontrol II can be programmed through the operating panel and has been protected against unauthorized use by a password. A pressure reader that is mounted on the outlet side passes the system pressure on to the Megacontrol II using an analog signal.

The Megacontrol II ensures that the pressure in the system remains equal to the preset value. For this the pumps are individually switched on and off. This after-run time of the pumps is continuously optimised. The supply can have been configured in three ways.

1. Pressure reader in supply line.

A pressure reader can be mounted in the supply line. This reader records the supply pressure for:

- The PID-control.
- Reading in the display.
- The run-dry protection.

2. Pressure switch at suction side or float switch in receiver tank.

In the receiver tank (or in the supply line) a pressure switch or float switch can be mounted. This switch records the supply pressure for:

- The run-dry protection.

3. Pressure reader in receiver tank and supply valve.

A pressure reader can be mounted in the receiver tank. The pressure reader records the water level for:

- High-water alarm.
- Control of the supply valve. The supply valve can optionally be open/closed or proportionally controlled.
- Critical water-level indication.
- Run-dry protection.
- Two digital contacts for two extra level reports.

Hydro-unit MCF

The hydro-unit MCF has been equipped with one or more frequency controllers. If the hydro-unit is rotation-controlled, a pressure reader has been mounted on the outlet side of the installation that passes the system pressure on to the Megacontrol II using an analogue signal. An integrated adjustable PID-controller in the software of the Megacontrol II ensures that the system pressure remains constant by successively switching on or off one or more (whether or not) rotation-controlled pumps with delay. A pump is only switched on when 100% or 0% respectively of the speed has been reached.

Hydro-unit MCJ

The hydro-unit MCJ is fitted with a jockey pump, which is especially suited for installations with strongly fluctuating water consumption. The jockey pump is a smaller pump with less capacity but the same pressure as the main pumps of the installation. A pressure reader that is mounted on the outlet side passes the system pressure on to the Megacontrol II using an analogue signal. The jockey pump will be started first. If the water consumption is larger than the capacity of the jockey pump, one or more main pumps will be switched on, whereas the jockey pump is switched off. When the water consumption drops the jockey pump will take over the function of the

main pumps again. If the capacity of the main pumps is not sufficient, in case of a large water consumption, the jockey pump will also be switched on. A hydro-unit can also be fitted with 2 jockey pumps which are each other's backups.

6 Transport

6.1 Transport and storage

1. Transport the control unit in the position as indicated on the pallet or packaging.
2. Check if the control unit is stable.
3. Observe the instructions on the packaging (if present).



ATTENTION

Store the control unit in a dry and dust-free place.

7 Install

7.1 Mechanical install



ATTENTION

Contact the supplier if parts are missing or damaged.

Build in the control unit using suitable fastening material. Consult the annexe "Build-in diagram" for the correct overall dimensions.

7.2 Electrical install



WARNING

Only authorized personnel is allowed to connect the control unit electrically in accordance with the local regulations.

Electrical connections

- Make sure that the electric control unit specifications correspond with the power supply to which is connected.
- Consult the annex "Electrical diagram" for a list of all electrical power points.

7.3 Commissioning

Adjust the installation by setting the parameters for the Megacontrol II. For this set the required values for each parameter. See the annexes for a list of all available parameters. Also see "Read/set parameters".

8 Operation

8.1 Display

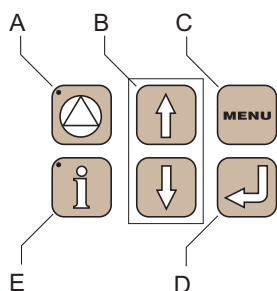

Operating panel

The system can be adjusted using the push buttons and the display on the operating panel. The display has two lines. When the system is in normal operation, the current system values will be shown on the display (start screen). On the start screen the upper display line shows the current system values (system pressure [kPa] / total pump load [%]). The current system values shown on the lower display line are dependent on the system configuration:

Configuration	Lower line
1. Pressure reader in supply line.	Supply pressure [kPa]
2. Pressure switch at suction side or float switch in receiver tank.	Water present
3. Pressure reader in receiver tank and supply valve.	Water level [%] / Valve position [%]

Apart from showing the current system values on the start screen on the display, the operating panel is also used for the following operations:

- Retrieve pump information.
- Show failure messages.
- Read and/or set parameters.

8.2 Retrieve pump information

Pump information can be retrieved for each individual pump. For each pump the following pump items can be selected successively:

Pump item	Meaning
Automatic	Pump status. An asterisk (*) following the pump item indicates the current pump status.
Manual operation	
Switched off	
Operating hours	The total number of operating hours.
Number of starts/h	The average number of starts per hour
Failures	Recorded failures.

In order to retrieve the information about a pump, proceed as follows:

- 1 Select the required pump by repeatedly pushing the button.
- 2 Use the buttons to select the required pump item. The current value of the pump item is shown on the lower display line.
- 3 Press the button to change the pump status.



WARNING

When a pump has been switched off, the green LED will flash to indicate this.





WARNING

Remember to put all pumps in the automatic position before putting the system into use (again). The green LED "In operation" will light up continuously.

8.3 Show failure messages

At the moment that a failure occurs, the red LED "Failure" will light up in the failure information button. In order to obtain information about the current failure, proceed as follows:





- 1 Press the failure information button . The upper display line shows the cause of the failure, the lower display line shows the date and the time the failure occurred. The symbol ">" following a failure message indicates that an explanation will follow automatically after three seconds. The explanation gives extra information about the current status of the installation and the remedies for most failures.
- 2 Remedy the failure
- 3 Press the failure information button  to return to the start screen. The red LED "Failure" will switch off and the failure message will be saved in the failure memory.



ATTENTION

Press the button  when prompted.

To view all messages saved in the failure memory:

- 1 Press the failure information button . The most recent failure message will be shown.
- 2 Use the buttons   to scroll through the failure memory
- 3 Press the failure information button again  to return to the start screen.

For an overview of all possible failure message, see the table in the annexes.

8.4 Read/set parameters







8.4.1 Enter password

Before being allowed to set any parameters, the password is to be entered. The password secures the set parameters against unauthorized changes. There are three security levels:

Table 3: Security levels







Level	Password	Authorities
Read-only	None	Read all parameters.
Supervisor	7	Read all parameters and set a limited number of parameters.
Maintenance	Only available to technical staff of Duijvelaar Pompen BV.	Read all parameters and set all parameters.

To enter the password, proceed as follows:

- 1 Press the menu button .
- 2 Use the buttons   to select the required level.
- 3 Press the button  to activate the selection.
- 4 Dependent on the selected level: enter the password. Use the buttons for this  . Press the button  to activate the password.

8.4.2 Read/set parameters

After the password has been entered, the parameter menu is opened. To read and/or set parameters, proceed as follows:

- 1 Use the buttons   to select parameters. The upper display line shows the selected parameter, the lower display line shows the value of it.
- 2 Press the button , to be able to set the value of a parameter. If there is a submenu behind the parameter, the parameters of this are automatically shown. Use the buttons   to select the parameters of the submenu.
- 3 Press the menu button  to return to the start screen. The active security level will remain accessible for 1 hour. By pressing the menu button again  and selecting 'Read-only', the system returns to the 'Read-only' mode.

9 Annexes

9.1 Megacontrol II

Table 4: Technical specifications

Item	Value
Type of control	Megacontrol II
Article number	77870004
Dimensions HxWxD	270x210x65
Connecting voltage [V]	220 - 240
Frequency [Hz]	50 - 60 ± 5%
Relay outputs [A]	1 max.
Analog inputs [mA]	4 - 20 (10 bits)
Analog outputs [mA]	0 - 20 (8 bits)
Safety class	IP54
Display	2 lines x 20 characters
Ambient temperature [°C]	50 max.
Atmospheric humidity [%]	20 - 90 (no condensation)
Fuse [mA]	125 (250V) ¹

1. Is found in the plug of the connection

9.2 Build-in diagram

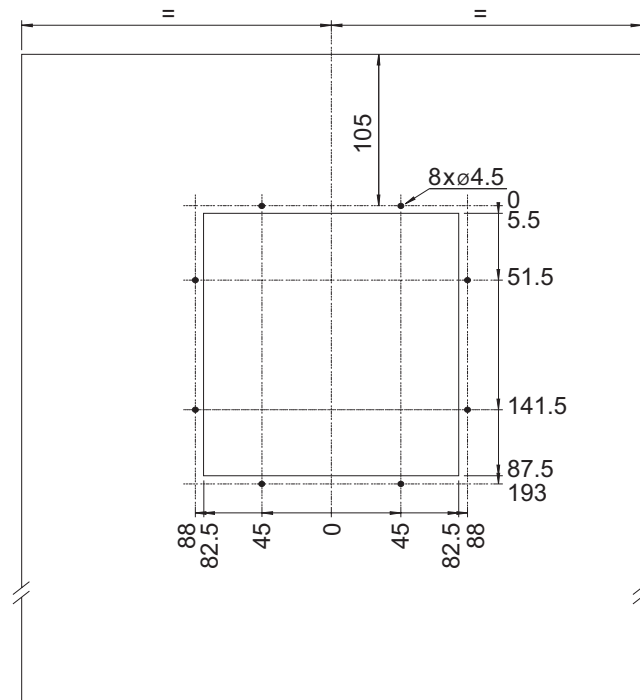

Build-in diagram Megacontrol II

9.3 Electrical connections

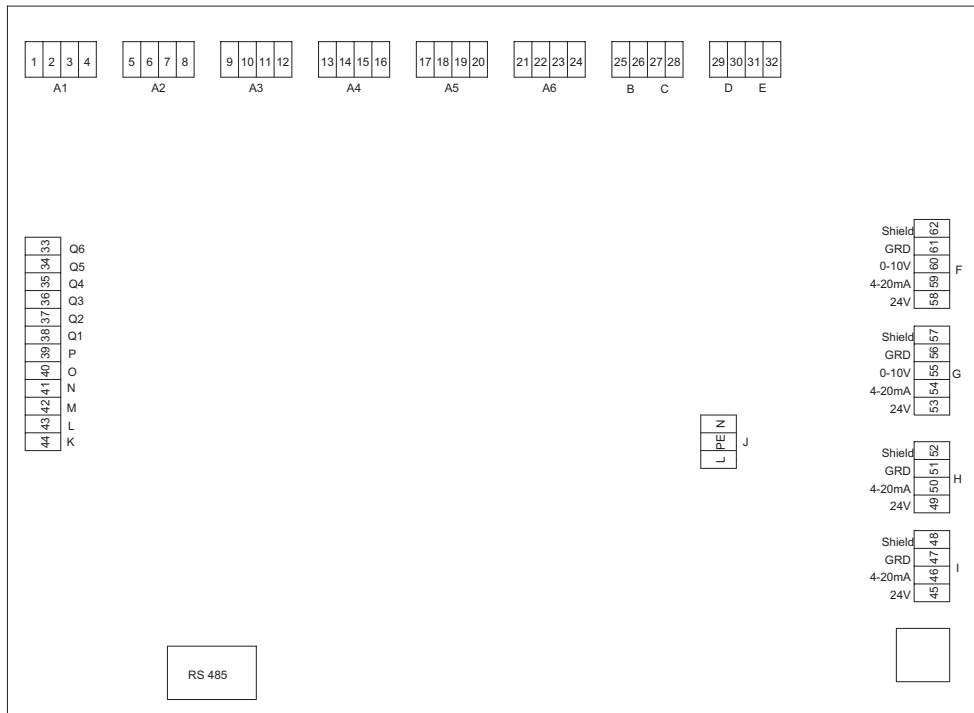

Components of the printed circuit-board of Megacontrol II

No.	Connection	No.	Connection
A1	Pump 1	J	Power supply
A2	Pump 2	K	M connection
A3	Pump 3	L	Thermal failure frequency converter
A4	Pump 4	M	Thermal failure supply valve
A5	Pump 5	N	Run-dry protection
A6	Pump 6	O	External stop
B	Control of supply valve	P	Fire alarm
C	Start/stop frequency converter	Q1	Thermal failure pump 1
D	Failure "Urgent"	Q2	Thermal failure pump 2
E	Failure "Not Urgent"	Q3	Thermal failure pump 3
F	Frequency converter	Q4	Thermal failure pump 4
G	Supply valve (proportional)	Q5	Thermal failure pump 5
H	Outlet pressure	Q6	Thermal failure pump 6
I	Suction side		

9.4 Parameter list

The parameters of the main menu are related to the basic settings of the installation. There are 'basic' and 'default' parameters. The basic settings can be adjusted as needed and under all circumstances be retrieved again. An installation typically functions on the basis of the set default parameters. Supplementary, extra parameters can be used that are defined in the submenus 'advanced' 'pressure', 'delay' and 'clock'. In order to be able to use these extra parameters, the respective submenus are to be activated.



ATTENTION

Y (yes) in the column SV (Supervisor) indicates that a parameter can be set at the supervisor security level.



ATTENTION

If one or more parameters are missing, you probably have a Megacontrol II with obsolete software. Contact DP-Pumps for an upgrade of the software. The software versions are shown on the display for three seconds, after the Megacontrol II has been switched on.

Table 5: Software version management Megacontrol II

Version	Adjustment	Version	Adjustment
V0.31	Field test.	1.30	Menu maximum power added.
V1.00	Final version	1.32	Menu threshold added.
V1.2	Optimisation of proportional valve and jockey pump control.	1.35	Lecom B communication and autoreset fire alarm added.
V1.27	Write to flash memory improved.	1.42	Danfoss communication added

9.4.1 Main menu

Parameter	SV	Value	Use
Setpoint	Y	0-9999 [kPa]	Set pressure of the installation. When aiming at the set pressure, all connected pumps are switched on and off or the rotation is controlled, dependent on the configuration selected. [Basic: 400 kPa]
Display	Y	Nederlands English Deutsch Francais	Language used for the messages on the display. This language selection only applies to the start screen and to the failure messages. [Basic: English]
Number of pumps		1-6	The total number of active pumps of the installation. [Basic: 3]
Suction		Switch Pressure Level	Configuration at the suction side of the installation as under-pressure or run-dry protection: <ul style="list-style-type: none"> 1. Pressure: Pressure reader (analog 4-20 mA). 2. Switch: Pressure or float switch (digital). 3. Level: Level reader (analog 4-20 mA). [Basic: Switch]
Control		Frequency Jockey Fixed speed	Configuration on the outlet side of the installation: <ul style="list-style-type: none"> Frequency: Rotation-controlled pump(s) with frequency controller(s). Jockey: One or two jockey pumps have been included in the installation. Fixed speed: Pumps with fixed speed. [Basic: Frequency]
Advanced Pressure		On Default	Activate (On) or deactivate (Default) the extra settings in the submenu 'Advanced Pressure'. [Default: Default settings]
Advanced Delay	Y	On Default	Activate (On) or deactivate (Default) the extra settings in the submenu 'Advanced Delay'. [Default: Default settings]
Advanced Clock	Y	On Default	Activate (On) or deactivate (Default) the extra settings in the submenu 'Advanced Clock'. [Default: Default settings]
Internet setting			This menu becomes visible when a pico server has been connected.
01-01-2000 12:12	Y		Current date and time.
Restore basic settings?		Are you sure? No/Yes	Reload the 'basic settings'. The basic settings are part of the factory settings and form the basis for further adjustment of the installation. The factory settings are overwritten by this. This requires a password. This option is only available to technical staff of Duijvelaar Pompen BV.
To read only mode	Y	Permanent display	Return to 'Read-only' security level.

9.4.2 Submenu - Suction: switch

Parameter	SV	Value	Use
Reset		Manual Automatic	Reset or restart the installation, after the correct supply pressure has been reached or the correct level has released the installation. Dependent on the parameter value resetting is done automatically or manually. [Default: Manual]
Run dry delay	Y	0-300 [s]	Delay in the switch-off command of the run-dry protection. [Default: 10 s]
Inlet pressure	Y	0-999 [kPa]	Average supply pressure. [Default: 200 kPa]
Return to main menu			Return to main menu.

9.4.3 Submenu - Suction: pressure

Parameter	SV	Value	Use
Sensor 4 mA		-100 to - 999 [kPa]	Calibration value of the applied pressure reader, while 4 mA is sent (read from the housing of the reader). [Default: 0 kPa]
Sensor 20 mA		0-9999 [kPa]	Calibration value of the applied pressure reader, while 20 mA is sent (read from the housing of the reader). [Default: 1000 kPa]
Reset		Manual Automatic	Reset or restart the installation, after the reaching of the reset pressure has released the installation. Dependent on the parameter value, resetting is done automatically or manually. The reset value can be entered at the parameter 'Reset at' that follows this. [Default: Manual]
Shut down at		0-9999 [kPa]	Switch-off pressure of the installation as underpressure protection at the suction side: [Default: 20 kPa]
Reset at		0-9999 [kPa]	Reset value at which the installation is released. [Default: 80 kPa]
Run dry delay	Y	0-300 [s]	Delay in the switch-off command. [Default: 10 s]
Reference pressure		Off - 9999 [kPa]	Adjustable minimum suction pressure. When the supply pressure exceeds this value, the surplus value is added to the set value. This keeps the difference between the switch-on pressure and the maximum pressure of the pump at a minimum in case of heavily fluctuating supply pressures. [Default: Off]
Return to main menu			Return to main menu.



9.4.4 Submenu - Suction: level

Parameter	SV	Value	Use
Sensor 4 mA		-100.0 to -99.9 [kPa]	Calibration value of the applied level reader, while 4 mA is sent (read from the housing of the reader). [Default: 0 kPa]
Sensor 20 mA		0-999.9 [kPa]	Calibration value of the applied level reader, while 20 mA is sent (read from the housing of the reader). [Default: 30 kPa]
0% level at		0 - 99 [cm]	The lowest possible level in the receiver tank (in relation to the bottom) at which no air is sucked in. [Default: 0 cm]
100% level at		0 - 999 [cm]	The highest possible level in the receiver tank (in relation to the bottom) before the overflow is triggered. [Default: 200 cm]
Sensor level		-100 to -999 [cm]	The mounting height of the level reader in the receiver tank (in relation to the bottom) This value may also be negative in case the reader has been mounted below the bottom. [Default: 0 cm]
Shut down at	Y	0 - 99 [%]	[Default: 10%]
Reset	Y	Manual Automatic	Reset or restart the installation, after the reaching of the reset value of the level reader has released the installation. Dependent on the parameter value, resetting is done automatically or manually. The reset value can be entered at the parameter 'Reset at' that follows this. [Default: Automatic]
Reset at	Y	0 - 99 [%]	Reset value at which the installation is released. [Default: 15%]
Critical at	Y	0 - 99 [%]	Critical level at which the tank threatens to become empty. [Default: 30%]
High water at	Y	0 - 999 [%]	High-water level at which the tank threatens to become overfull. [Default: 105%]
Supply valve		On/Off Proportional	Control of the supply valve. The supply valve with which the receiver tank is filled can optionally be open/closed or proportionally controlled. Dependent on the selection made, a corresponding submenu will be activated (see below). [Basic: On/Off]
Threshold	Y	On/Off	Menu for having one or two extra contacts switched at a level set as required (see sub threshold).
Return to main menu			Return to main menu.

9.4.5 Submenu - Valve: on/off

Parameter	SV	Value	Use
Level 1 open	Y	0 - 99.9 [%]	Level in the receiver tank at which the supply valve is opened. [Default: 70%]
Level 1 closed	Y	0 - 99.9 [%]	Level in the receiver tank at which the supply valve is closed. [Default: 90%]
Level 1A open	Y	0 - 99.9 [%]	Alternative level in the receiver tank at which the supply valve is opened. The switch from level 1A to level 1 takes place on an adjustable date (see submenu 'advanced clock'). [Default: 40%]
Level 1A closed	Y	0 - 99.9 [%]	Alternative level in the receiver tank at which the supply valve is closed. The switch from level 1A to level 1 takes place on an adjustable date (see submenu 'advanced clock'). [Default: 60%]
Return to sub menu			Return to submenu.

9.4.6 Submenu - Valve: proportional

Parameter	SV	Value	Use
Level setpoint 1	Y	0 - 99.9 [%]	Maximum level in the receiver tank at which the proportional valve is fully closed. [Default: 80%]
Level setpoint 1A	Y	0 - 99.9 [%]	Alternative level in the receiver tank at which the proportional valve is fully closed. The switch from level 1A to level 1 takes place on an adjustable date (see submenu 'advanced clock'). [Default: 40%]
Hysteresis	Y	0 - 99.9 [%]	Maximum level in the receiver tank minus the hysteresis is the level at which the proportional valve is fully open. [Default: 15%]
Sampling time	Y	0-99 [s]	Time between the measurements controlling the proportional valve. [Default: 10 s]
Return to sub menu			Return to submenu.

9.4.7 Submenu - Threshold: On

Parameter	SV	Value	Use
Level 2 on ¹	Y	0 - 99.9 [%]	Level at which the contact becomes 'high' (digi P6).
Level 2 off ¹	Y	0 - 99.9 [%]	Level at which the contact becomes 'low' (digi P6).
Level 3 on ²	Y	0 - 99.9 [%]	Level at which the contact becomes 'high' (digi P5).
Level 3 off ²	Y	0-99 [s]	Level at which the contact becomes 'low' (digi P5).
Return to sub menu			Return to the submenu.

1. Applicable at a maximum of five pumps.
2. Applicable at a maximum of 4 pumps.



9.4.8 Submenu - Control: frequency

Parameter	SV	Value	Use
Control		Change over Fixed all Fixed one	The motors of the pumps are rotation-controlled by using one or more frequency controllers: <ul style="list-style-type: none"> • Change over: 1 frequency controller in the switch box is switched to the motors included in the system. • Fixed one: 1 frequency controller in the switch box or integrated in the motor that is not switched to the other motors included in the system. • Fixed all: Each motors has a frequency controller (integrated or in the switch box) that is not switched to the other motors included in the system. [Basic: Fixed one]
Communication		Analog Serial LECOM B Serial Danfoss	Communication between the Megacontrol II and the frequency controllers: <ul style="list-style-type: none"> • Analog: analog 0-20 mA signal, a start/stop command and a general failure message. • Serial LECOM B: Via the serial port following the standard protocol of the LENZE frequency controller. • Serial Danfoss: Via the serial port following the standard protocol of the Danfoss frequency controller. [Basic: Analog]
Proportional constant		0 - 99.9	Proportional constant. Proportional amplification factor the required system pressure is controlled with. [Basic: 10.0]
Integration constant		0 - 99.9	Integration constant. Speed with which the deviation of the required system pressure is adjusted back. [Basic: 1.0]
Differentiation constant		0 - 99.9	Differentiation constant. The level of damping with which the deviation of the required system pressure is controlled. [Basic: 0.5]
No flow detection		Off - 10 [%]	Accuracy of the switch-off procedure 'no-flow'. [Basic: 5%]
Pump pressure		0-9999 [kPa]	No-load pressure of the pump [Basic: 400 kPa]
Rel. pump		0 - 100 [%]	Power of a next pump in relation to the first pump. [Basic:95%]
Accu. pressure		0-999 [kPa]	Shortly before switching off the entire installation, the system pressure can be increased so as to fill the connected membrane switch vessels. This overpressure serves as accumulation in the system to prevent starting up of the system at a minimum pressure drop. [Basic: 25 kPa]
Bandwidth		0-100 [kPa]	The system will continuously keep controlling in order to approach the system pressure as closely as possible. With the bandwidth a 'dead' area can be created within which the power sent to the converter remains constant. [Basic: 5 kPa]
100% delay		0-99 [s]	The time before a next pump is switched on as well. [Basic: 5 s]
Write Node ID ¹		Off !!!	Set the slave address at serial communication. This setting must be 'Off' for the installation to be able to work.
Ramp up ¹		0-99 [s]	Ramp-up, from zero to maximum speed
Ramp down ¹		0-99 [s]	Ramp-down time, from maximum speed to zero.
Min. freq.		0 - 60 [Hz]	Minimum frequency of the frequency converter.
Max. freq.		0 - 60 [Hz]	Maximum frequency of the frequency converter.

Parameter	SV	Value	Use
Un		0-999 [V]	Nominal Voltage of the motor (only serial danfoss)
In		0-999 [A]	Nominal Amperage of the motor (only serial danfoss)
Pn		0-999 [kW]	Nominal Power of the motor (only serial danfoss)
n n		0-9999 [rpm]	Nominal speed of the motor (only serial danfoss)
Return to main menu			Return to the main menu.

1. Only visible when making use of serial communication.

9.4.9 Submenu - Control: jockey

Parameter	SV	Value	Use
Control		One Two	The pump(s) 1 and/or 2 have been selected as jockey pump and will always be switched on first. If a main pump is switched on due to a capacity increase, the jockey pump is switched off. <ul style="list-style-type: none"> • One: One pump (pump 1) has been selected as jockey pump. • Two: Two pumps (pumps 1 and 2) have been selected as jockey pumps and are each other's backups. [Default: One]
Return to main menu			Return to main menu.

9.4.10 Submenu - Internet settings

Parameter	SV	Value	Use
Halt server	Y	On/Off	Safely switches off the pico server.
Password	Y		The password for the pico server to get access to the Internet.
Phone number	Y		The telephone number that the pico server has to call for getting access to the Internet. Here enter an extra zero if this is required with respect to an outside line.
Username	Y		Username for the pico server for getting access to the Internet.
Return to main menu			Return to the main menu.



9.4.11 Submenu - Advanced pressure

The parameters of the submenu are related to the pressure settings of the installation. The values set here are only active when the 'advanced pressure' submenu has been activated from the main menu (on).

Parameter	SV	Value	Use
Sensor 4 mA		-100 to -9999 [kPa]	Calibration value of the applied pressure reader, while 4 mA is sent (read from the housing of the reader). [Default: 0 kPa]
Sensor 20 mA		0-9999 [kPa]	Calibration value of the applied pressure reader, while 20 mA is sent (read from the housing of the reader). [Default: 1000 kPa]
Max. Setpoint		Off - 9999 [kPa]	Upper limit for the value to be set. [Default: Off]
Delta-P correction		Off - 9999 [kPa]	Value with which the set value is automatically corrected. The first pump will switch on at 'set pressure minus Delta-P correction'. With each pump that is switched on the set pressure value is automatically increased quadratically, which creates a function that is equal to the pipe resistance characteristic. [Default: Off]
Over pressure		Off Setpoint - 9999 [kPa]	Upper limit value for the system pressure. [Default: Off]
Over pressure		Signal Shut down	Required action at reaching the upper limit value of the system pressure. <ul style="list-style-type: none"> Signal: A signal is generated. Shut down: The system is switched off. Default: Signal
Under pressure		0 to -Setpoint [kPa] Off	Lower limit value for the system pressure. [Default: Off]
Under pressure		Signal Shut down	Required action at reaching the lower limit value of the system pressure. <ul style="list-style-type: none"> Signal: A signal is generated. Shut down: The system is switched off. Default: Signal
Hysteresis		0-9999 [kPa]	Bandwidth above and below the set pressure at which the pump(s) are switched on and off. [Default: 30 kPa]

Parameter	SV	Value	Use
Daily setpoint	Y	0-9999 [kPa]	Alternative set pressure value. The switch to the alternative set pressure takes place every day at the same time and will be active for an adjustable time (see submenu 'advanced clock'). [Default: 0 kPa]
Weekly setpoint	Y	0-9999 [kPa]	Alternative set pressure value. The switch to the alternative set pressure only takes place on the selected day of the week and will be active for an adjustable time (see submenu 'advanced clock'). [Default: 0 kPa]
Pumps ON sens. fail.	Y	0 - 5	The number of pumps that is automatically started as temporary provision in case of a failure of the pressure sensor on the outlet side. The pump(s) will then, independent of the system pressure, be continuously in operation. Maximum number = Total number of pumps - 1. [Default: 1]
Max. power		0 - 600[%]	Limitation of the maximum power (1 pump = 100%)
Return to main menu			Return to the main menu.

9.4.12 Submenu - Advanced delay

The parameters of this submenu are related to the switch-on and switch-off delays of the pumps and signals. The values set here are only active when the 'advanced delay' submenu has been activated from the main menu (on).

Parameter	SV	Value	Use
Maximum pump starts		0 - 99 [h ⁻¹]	The maximum number of starts a pump (motor) is allowed to make per hour. The after-run time (switch-off delay) of the pump is automatically corrected based on this. [Default: 10 h ⁻¹]
Sampling time		0 - 99 [min]	The time interval in which the average number of pump starts per hour is measured. [Default: 60 min]
Minimum stop delay		0-9999 [s]	The minimum after-run time of a pump. [Default: 90 s]
Stop delay correction		0-99 [s]	After-run time correction value. [Default: 0 s]
Actual stop delay		(read only) [s]	The after-run time calculated by the installation.
100% delay		0-99 [s]	Switch-on delay after which the next pump is really needed. [Default: 1 s]
Start delay		0-999 [s]	Switch-on delay after which the pumps are switched on (if pressure remains low). [Default: 2 s]
Deviation delay		0-999 [s]	Delay with which the installation will be switched off, after the upper or lower limit value of the set pressure has been reached (overpressure and underpressure parameters). [Default: 60 s]
Return to main menu			Return to the main menu.

9.4.13 Submenu - Advanced clock

The parameters of this submenu are related to the date and/or time-bound adjustment of a number of parameter settings. The values set here are only active when the 'advanced clock' submenu has been activated from the main menu (on).

Parameter	SV	Value	Use
Check run at	Y	Off 00.00 - 24.00 [h]	Time of check run. All pumps that have not run during the last 24 hours will start up one at a time (rotation-controlled ¹). Any failure messages will be ignored. [Default: Off]
Check run duration	Y	0-99 [s]	Time duration of check/run period. [Default: 10 s]
Maximum pump run	Y	Off 0 -9999 [min]	Maximum operation duration for a pump. After that another pump will be switched on. This prevents a pump from being in operation continuously at constant drop. [Default: Off]
Day setpoint On	Y	Off 00.00 - 24.00 [h]	Time that the alternative set pressure value (daily setpoint) becomes active. This switch takes place every day. [Default: Off]
Day setpoint Off	Y	Off 00.00 - 24.00 [h]	Time that the alternative set pressure value (daily setpoint) becomes inactive. This switch takes place every day. [Default: Off]
Week setpoint On Mo, Tu, We, Th, Fr, Sa, Su	Y	Off 00.00 - 24.00 [h]	Time that the alternative set pressure value (weekly setpoint) becomes active. This switch takes place only on the selected day of the week. [Default: Off]
Week setpoint Off Mo, Tu, We, Th, Fr, Sa, Su	Y	Off 00.00 - 24.00 [h]	Time that the alternative set pressure value (weekly setpoint) becomes inactive. This switch takes place only on the selected day of the week. [Default: Off]
Level 1A On	Y	Off mm-dd	Date on which the alternative level in the receiver tank (level setpoint 1A) becomes active. [Default: Off]
Level 1A Off	Y	Off mm-dd	Date on which the alternative level in the receiver tank (level setpoint 1A) becomes inactive. [Default: Off]
Maintenance interval		Off 0 - 9999 [h]	Number of operating hours after which a message is given that the installation needs inspection. [Default: Off]
Return to main menu			Return to the main menu.

1. Provided that the installation has this option.

9.4.14 Submenu - Real time

The current time and date can be set using the parameters of this submenu. Failure messages are saved and clock-related functions controlled on the basis of the current time and date.

Parameter	SV	Value	Use
Year	Y	1999 - 2099	Current year. [Default: 2000]
Month	Y	1 - 12	Current month. [Default: 1]
Day	Y	1 - 31	Current day. [Default: 1]
Day name	Y	Monday Tuesday Wednesday Thursday Friday Saturday Sunday	Name of the current day. [Default: Monday]
Hours	Y	0 - 23	Current hour. [Default: 0]
Minutes	Y	00 - 59	Current minute. [Default: 00]



9.5 Failure messages

The table gives an overview of all possible failure messages. All urgent failures are indicated separately. A failure is considered to be urgent when several pumps have failures at the same time.

Table 6: Failure messages Megacontrol II

Message	Explanation	Urgent
no failures	> no failures in memory	
pump. therm.off	> pump switched off, remedy failure and press 'enter' for reset	Y
supply valve therm.off	> supply valve switched off, remedy failure and press 'enter' for reset	Y
failure freq. conv.	> general failure frequency converter	Y
sensor failure supply	> sensor signal supply side not OK	Y
sensor failure outlet	> sensor signal outlet side not OK	Y
outlet pressure too low	> signal, system remains operational > system switched off, automatic reset	Y
outlet pressure too high	> signal, system remains operational > system switched off, automatic reset	Y
no water supply	> system switched off, press 'enter' for reset > system switched off, automatic reset	Y
suction pressure too low	> system switched off, press 'enter' for reset > system switched off, automatic reset	Y
water level too low	> system switched off, press 'enter' for reset > system switched off, automatic reset	Y
critical level	> receiver tank almost empty, system remains operational	
fire alarm	> all pumps in operation, press 'enter' + code for reset	Y
external off	> system externally switched off, automatic external reset	
high-water alarm	> receiver tank too full, automatic reset	
inspection required	> for preventive maintenance: > DP-service division +31 (0)172-488366	
hardware error	> system needs to be readjusted code: EEPROM 1 INTERNAL_RAM 2 EXT_WATCHDOG 3 EPROM 4 SOFTWARE_FAIL 5 EXT_RAM 6 STACK_OVERFLOW 7 RTC 8 UART_TEST 9 I2C 10 EEPROM_2 11 24_VOLT 12 DAC 13	Y
reset failures	> delete the last failures and total error reset, press 'enter' + code	
FO ?? fault no ?? ¹	> fo failure, remedy error and press 'enter' for reset	

1. Consult the manual of the frequency converter to look up the failure number and consequently the cause of the failure.

9.6 Factory settings

Note the factory settings in the parameter list below. On the basis of these data the factory settings can be restored at all times.



WARNING

The settings may never be changed by unauthorized persons.

	Factory			IBS		
Date						
Initials						

	Setting	
Setpoint	kPa	kPa
Display	Ned / Eng / Deu / Fra	
Number of pumps	1 / 2 / 3 / 4 / 5 / 6	
Suction	Switch / Pressure / Level	
Control	Frequency / Jockey / Fixed speed	
Adv. pressure	On / Default	
Adv. delay	On / Default	
Adv. clock	On / Default	

Table 7: Submenu: suction

Suction switch	Setting	
Reset	Manual / Automatic	Manual / Automatic
Run dry delay	s	s
Inlet press.	kPa	kPa

Suction pressure	Setting	
Sensor 4mA		kPa
Sensor 20mA		kPa
Reset	Manual / Automatic	Manual / Automatic
Shut down at	kPa	kPa
Reset at	kPa	kPa
Run dry delay	s	s
Ref. press.	kPa	kPa

Suction level	Setting	
Sensor 4mA		kPa
Sensor 20mA		kPa
0% level at	cm	cm
100% level at	cm	cm
Sensor level	cm	cm
Shut down at	%	%
Reset	Manual / Automatic	Manual / Automatic

Suction level	Setting	
Reset at	%	%
Critical at	%	%
High water at	%	%
Supply valve	On / Off / Proportional	
Threshold	On/Off	

Supply valve On-Off	Setting	
Level 1 open	%	%
Level 1 closed	%	%
Level 2 open	%	%
Level 2 closed	%	%

Supply valve Proportional	Setting	
Level setp. 1	%	%
Level setp. 2	%	%
Hysteresis	%	%
Sampling Time	s	s

Threshold	Setting	
Level 1 on	%	%
Level 1 off	%	%
Level 2 on	%	%
Level 2 off	%	%

Table 8: Submenu: Control frequency

Control frequency	Setting	
Control	Change over / Fixed all / Fixed 1 / Fixed 2	
Communication	Analogue / Iecom B	
Prop. const.		
Int. const.		
Diff. const.		
No flow detect.		
Pump press.	kPa	kPa
Accu. press.	kPa	kPa
Bandwidth	kPa	kPa
100% delay	s	s
Write node ID		
Ramp up	s	s
Ramp down	s	s
Min. frequency	Hz	Hz
Max. frequency	Hz	Hz

Table 9: Submenu: Control jockey

Control jockey	Setting
Control	1 jockey / 2 jockey

Table 10: Submenu: Internet settings

Internet settings	Setting
Halt server	On/Off
Password	
Phone number	
Username	

Table 11: Submenu: Advanced pressure

Advanced pressure	Setting
Sensor 4mA	kPa
Sensor 20mA	kPa
Max. setp.	kPa
Delta-P corr.	kPa
Over press.	kPa
Over press.	Signal / Shutdown
Under press.	kPa
Under press.	Signal / Shutdown
Hysteresis	kPa
Daily setp.	kPa
Weekly setp.	kPa
Pumps ON sens. fail	0 / 1 / 2 / 3 / 4 / 5

Table 12: Submenu: Advanced delay

Advanced delay	Setting
Max. pump starts	/h
Sampling time	min
Min. stop delay	s
Stop delay corr.	s
Act. stop delay	Read Only
Start delay	s
Deviation delay	s



Table 13: Submenu: Advanced clock

Advanced clock	Setting			
Check run at		h		h
Check run durat.		s		s
Max. pump run		min		min
Day setp ON		h		h
Day setp OFF		h		h
Wk spON Mo.		h		h
Wk spOFF Mo.		h		h
Wk spON Tu.		h		h
Wk spOFF Tu.		h		h
Wk spON We.		h		h
Wk spOFF We.		h		h
Wk spON Th.		h		h
Wk spOFF Th.		h		h
Wk spON Fr.		h		h
Wk spOFF Fr.		h		h
Wk spON Sa.		h		h
Wk spOFF Sa.		h		h
Wk spON Su.		h		h
Wk spOFF Su.		h		h
Level 2 ON	mm	dd	mm	dd
Level 2 ON	mm	dd	mm	dd
Maint. interval		h		h

9.7 Declaration of conformity (IIB)

factory declaration (2.1) according to NEN-EN-10204

Undersigned:

DP-Pumps

Kalkovenweg 13

2401 LJ Alphen aan den Rijn, The Netherlands

Tel: (+31)(0)-172-48 83 21

Fax: (+31)(0)-172-46 89 40

Declares as manufacturer entirely on his own responsibility, that the products:

Product: Control units

Type: Megacontrol II

to which this declaration refers, is in accordance with the following standards:

EN-IEC-61000-6-1/3, EN-IEC-61000-3-2

EN-1010 and EN-60204-1

according to the provisions of (when applicable):

EMC directive 89/336/EEC

Low voltage directive 73/23/EEC

If the control unit is used as a stand-alone product, it is subject to this declaration of conformity.

If the control unit is built in an appliance or is assembled together with other equipment in certain installations, then it should not be put into operation until a declaration has been given with respect to the appliance concerned that it complies with the directives listed above.



Alphen aan den Rijn,

18-05-2006

Responsible person:

W. Ouwehand, technical director





dp pumps

dp pumps
P.O. Box 28
2400 AA Alphen aan den Rijn
The Netherlands

t +31 172 48 83 25
f +31 172 46 89 30

dp@dp-pumps.com
www.dp-pumps.com

11-2006

BE00000202

