

Submersible sewage pumps

Installation and operating instructions

series: DRV / DRK / DRS / DRSK

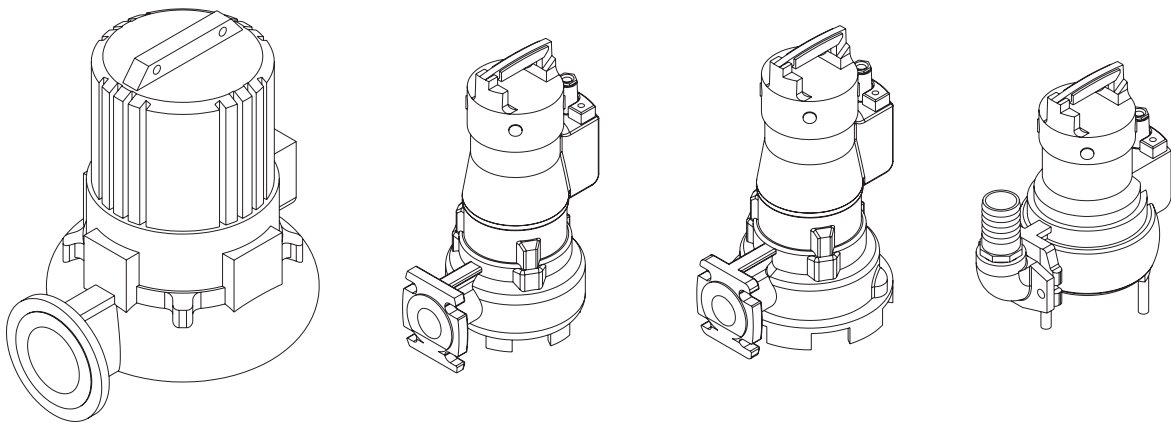

Table of Contents

1	Manual introduction	
1.1	Preface.....	3
1.2	Icons and symbols	3
1.3	Identification, service and technical support	3
1.4	Terms of warranty	4
1.5	Supplementary documentation	4
2	Safety and environment	
2.1	General	5
2.2	Users.....	5
2.3	Safety provisions.....	5
2.4	Safety precautions	6
2.5	Environmental aspects.....	6
3	Introduction	
3.1	General	7
3.2	Intended use	7
3.3	Working range.....	7
3.4	Operation	8
3.5	Operation of the automatic level regulation A-series	8
4	Transportation	
4.1	Transport.....	10
4.2	Storage.....	10
5	Installation	
5.1	Mechanical installation	11
5.2	Electrical installation	11
5.3	Commissioning	12
6	Operation	
6.1	Operation	13
7	Maintenance	
7.1	Maintenance	14
7.2	Taking out of operation for a long interval	15
8	Failures	
8.1	Failure table	16
9	Annexes	
9.1	Technical specifications	18
9.2	Electrical connections	20
9.3	Declaration of conformity (IIA)	21

1 Manual introduction

1.1 Preface

The manual contains important information for reliable, proper and efficient operation. Compliance with the operating instructions is of vital importance to ensure reliability and a long service life of the product and to avoid any risks.

The first chapters contain information about this manual and safety in general. The following chapters provide information about normal use, installation, maintenance and repairs of the product. The annexes contain the technical data, the parts drawings and the declaration(s) of conformity.

- Make yourself familiar with the content.
- Accurately follow the directions and instructions.
- Never change the sequence of the operations to be carried out.
- Keep this manual or a copy of it together with the logbook in fixed place near the product, which can be accessed by all personnel.

1.2 Icons and symbols

In this manual and in all accompanying documentation the following icons and symbols are used.



WARNING
Danger of electric tension. Safety sign according to IEC 417 - 5036



WARNING
Operations or procedures, if carried out without caution, may cause personal injury or damage to the product.
General hazard sign according to ISO 7000-0434



ATTENTION
Is used to introduce safety instructions whose non-observance may lead to damage to the product and its functions.



ENVIRONMENTAL INSTRUCTION
Remarks with respect to the environment.

1.3 Identification, service and technical support

You can identify the pump by the identification sticker that is found on the pump.

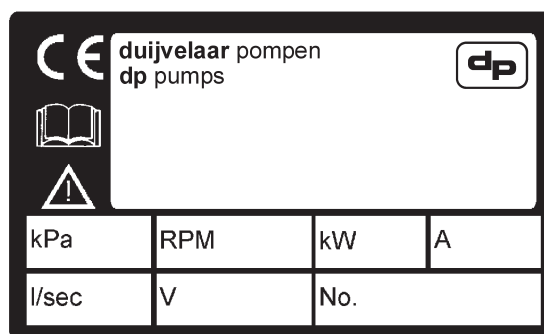

Indication	Meaning
DRV / DRK / DRS / DRSK	Pump type
kPa	Nominal pressure
l/sec	Nominal capacity
RPM	Nominal speed
V	Nominal voltage
kW	Motor power
A	Nominal current
No.	Serial number

The following address data are available for service and technical support:

DP-Pumps Kalkovenweg 13 2401 LJ Alphen a/d Rijn The Netherlands	Tel: +31 172 488325 Fax: +31 172 468930 Internet: www.dp-pumps.com E-mail: dp@dp-pumps.com
--	---

1.4 Terms of warranty

The warranty period is settled by terms of your contract or at least by the general terms and conditions of sales.



ATTENTION

Modifications or alterations of the product supplied are only permitted after consultation with the manufacturer. Original spare parts and accessories authorized by the manufacturer ensure safety. The use of other parts can invalidate any liability of the manufacturer for consequential damage.



ATTENTION

The warranty relating to the operating reliability and safety of the product supplied is only valid if the product is used in accordance with its designated use as described in the following sections of this manual. The limits stated in the data sheet must not be exceeded under any circumstances.

The warranty becomes invalid if one or more of the points below occur.

- The buyer makes modifications himself.
- The buyer carries out repairs himself or has these carried out by a third party.
- The product has been handled or maintained improperly.
- The product has non original DP-Pumps spare parts fitted.

DP-Pumps remedies defects under warranty if the points below are observed.

- Defects are caused by flaws in the design, the materials or the production.
- The defect has been reported within the warranty period.

Other terms of warranty have been included in the general terms of delivery, which are available upon request.

1.5 Supplementary documentation

As well as this manual, the documentation given below is also available:

Document	Date/version	Code
General terms of delivery	10-1998	119 / 1998
Documentation	11- 2005	97004429

2 Safety and environment

2.1 General

This DP-Pumps product has been developed in accordance with state-of-the-art technology; it is manufactured with utmost care and subject to continuous quality control.

DP-Pumps does not accept any liability for damage and injury caused by not observing the directions and instructions in this manual. This also applies in cases of carelessness during the installation procedure, use and maintenance of the product.

Non-compliance with safety instructions can jeopardize the safety of personnel, the environment and the product itself. Non-compliance with these safety instructions will also lead to forfeiture of any and all rights to claims for damages.

In particular, non-compliance can, for example, result in:

- failure of important pump/system functions,
- failure of prescribed maintenance and servicing practices,
- injury to persons by electrical, mechanical and chemical effects,
- hazard of the environment due to leakage of hazardous substances,
- explosions.

Depending on specific activities, extra safety measures may be required. Contact DP-Pumps if during use a potential danger arises.



ATTENTION

The owner of the product is responsible for compliance with the local safety regulations and internal company guidelines.



ATTENTION

Not only must the general safety instructions laid down in this chapter on "Safety" be complied with, but also the safety instructions outlined under specific headings

2.2 Users

All personnel involved in the operation, maintenance, inspection and installation of the product must be fully qualified to carry out the work involved.

Personnel responsibilities, competence and supervision must be clearly defined by the operator. If the personnel in question is not already in possession of the required know-how, appropriate training and instruction must be provided. If required, the operator may commission the manufacturer / supplier to take care of such training. In addition, the operator is responsible for ensuring that the contents of the operating instructions are fully understood by the responsible personnel.

2.3 Safety provisions

The product has been designed with the greatest possible care. Original parts and accessories meet the safety regulations. Modifications in the construction or the use of non-original parts may lead to a safety risk.



ATTENTION

Make sure that the product operates within its working range. Only then the product performance is guaranteed.

2.3.1 Labels on the product

The icons, warnings and instructions applied to the product are part of the safety provisions. The labels may not be removed or covered. Labels must remain legible during the entire life of the product. Replace immediately damaged labels.

2.4 Safety precautions

2.4.1 During normal use

- Contact the local electricity company for questions about the power supply.
- Shield parts that can become hot in such a way, that direct contact is impossible.
- When applicable, always place undeformed coupling protection plates to protect the coupling, before putting the pump into use. Make sure that the coupling protection plates are never in contact with the running coupling.
- Always close the switch box.

2.4.2 During installation, maintenance and repair

Only authorised personnel may install, maintain and inspect the product and repair electrical components. Observe the local safety regulations.



WARNING
Always disconnect the energy supply to the product first, before installation, maintenance and repairs. Secure this disconnection.



WARNING
Surfaces of a pump can be hot, after continuous operation.



WARNING
Make sure that no one can be near rotating components when starting a pump.



WARNING
Handle a pump with dangerous liquids with the utmost care. Avoid danger for persons or the environment when repairing leakages, draining liquids and venting. It is strongly recommended to place a relief barge under the pump.



WARNING
Immediately following completion of the work, all safety-relevant and protective devices must be re-installed and / or re-activated.



WARNING
Please observe all instructions set out in the chapter on "Commissioning/ Start-up" before returning the product to service.

2.5 Environmental aspects

2.5.1 General

The products of DP-Pumps are designed to function in an environmentally friendly way during their entire life. Therefore, when applicable, always use biodegradable lubricants for maintenance.



ENVIRONMENTAL INSTRUCTION
Always act according to the laws, by-laws regulations and instructions with respect to health, safety and the environment.

2.5.2 Dismantling

Dismantle the product and dispose of it in an environmentally friendly way. The owner is responsible for this.



ENVIRONMENTAL INSTRUCTION
Ask at the local government about the re-use or the environmentally friendly processing of discarded materials.

3 Introduction

3.1 General

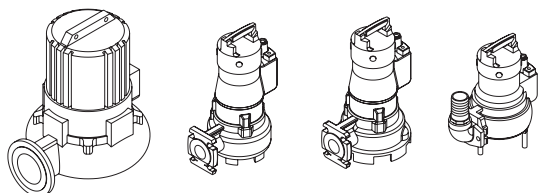

Submersible sewage pumps of the type DRV / DRK / DRS / DRSK

Submersible sewage pumps of the type DRV / DRK / DRS / DRSK are produced by DP-Pumps.

3.2 Intended use

The submersible pumps of the DRV / DRK / DRS / DRSK series are suitable for pumping the substances given below within the specified working range (see "Working range").

- Water with faeces.
- Water with solid or fibrous constituents.
- Sludge or thicker liquids.
- Clean or lightly contaminated wastewater.
- Rainwater.

Any other or further use of the pump is not in conformity with its intended use. DP-Pumps does not accept any liability for any damage or injury that results from this. The pump is produced in accordance with the current standards and guidelines. Use the pump only in a perfect technical state, in conformance with the intended use described below.

The *Intended use* as laid down in EN 12100-1 is the use for which the technical product is intended according to the specifications of the manufacturer. The use of the product has been described in the sales brochure and in the user manual. Always

observe the instructions given in the user manual. When in doubt the product must be used as becomes evident from its construction, version and function.

3.3 Working range

The working range of the submersible sewage pumps can be summarised as follows:

Table 1: Specification of the working range

Submersible sewage pump type	DRV	DRK	DRS	DRSK
Liquid temperature [°C]				
• maximum	40	40	40	55
• minimum	1	1	1	1
Free passage [mm]	35 - 135	35 - 135	none	65 - 76
frequency [Hz]	30 - 50	30 - 50	30 - 50	30 - 50

Table 2: Specific applications

Type	Application area
DRV	Pumping heavily contaminated liquids with solid and long staple constituents such as untreated sewage
DRK	Pumping lightly contaminated liquids with solid and long staple constituents
DRS	Shredding and pumping liquids with faeces and household wastewater.
DRSK	Pumping heavily contaminated liquids with solid and long staple constituents such as untreated sewage

3.4 Operation

The liquid is suctioned with a minimum supply pressure on the suction side (A). The pump increases the pressure. The liquid leaves the pump on the delivery side (B).

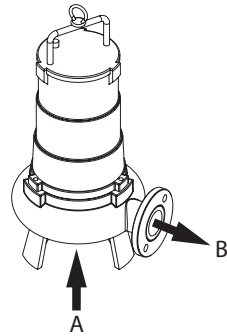

- A Suction side
- B Delivery side

Submersible sewage pumps that have been equipped with a build-in floater are automatically switched on and off when reaching a high or low liquid level respectively.

Solid constituents from the wastewater can pass the impeller without problems due to the large free passage opening of the submersible sewage pump. The performance (capacity and head) of the pump is determined by the motor power and the impeller type of the installed submersible sewage pump.

Table 3: Submersible sewage pump version

Type	DRV	DRK	DRS	DRSK
Impeller type	Vortex impeller	Channel impeller	Shredder (hardened stainless steel)	Non-clogging impeller
Safety class	IP68			
Insulation class	F			
Sealing	Double mechanical seal with intermediate oil chamber			

3.5 Operation of the automatic level regulation A-series

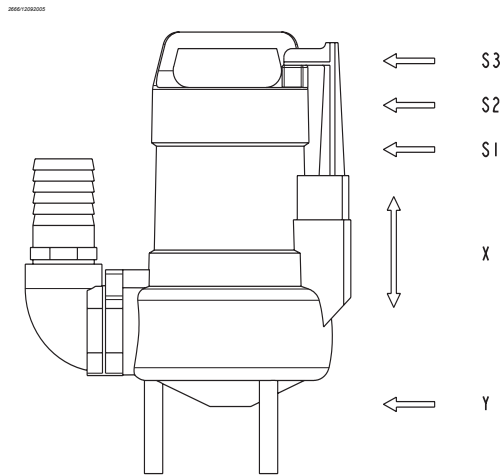

20050998

A-Series switching levels

3.5.1 One pump operation

The pump will randomly start at level S2 or S3 and will switch itself off at the lowest off switching level after the initiation phase. The times between the levels S3, S2 and S1 and the lowest off switching level are saved in the system memory.

The pump will start at level S2 or S3 during the following 7 switching cycles. The choice is random. The off switching moment will be calculated based on the number of saved starts between the levels S3, S2 and S1 and the lowest off switching level. When the pump has completed 7 switching cycles based on the previous calculation, the time measurements and the detection of the lowest off switching level is repeated and saved and the newly calculated pumping time is assigned to the pump. The time will be saved that is required to reach level S3, S2 or S1 when wastewater continues to flow in. The period during which the pump is operational will be adjusted to this.

When the pump has not been operational for a period of 24 hours, the pump will start until the lowest off switching level is detected. The test run will be automatically activated after every 24 hour period when the water level has not demanded a pump start.

The pump sends coded impulses to report failures. Special modules can decode these impulses and can specify the failures through failure lights or optical contacts.

3.5.2 Two pump operation

The different operational phases of the pump are combined through an algorithm in two pump operation which enables the pumps to recognise each other. The ratio of pumping times between levels S3, S2, S1 and the lowest off switching level are saved individually for each of the two pumps. The pumping time that is calculated is assigned to the following 7 pump cycles. Volume detection is performed independently after every eighth pump cycle.

The pumps can be operational simultaneously or in sequence because the choice for starting one of the pumps is random at level S2 or S3. When the water level drops to below level S1 in relation to a pump that is not operational, this pump will conclude that a partner pump is available. The information about there being a partner pump will be saved in the memory of both pumps. The pump that has just been operational, will save level S3 as the on switching level. The pump that was not operational and which detected the water level has dropped up to below level S1, will now save level S2 as the on switching level.

The two pumps will switch on in turns to on switching level S2 when the water level drops to below level S1 of the pump that was currently not operational. When the pumps have detected that there is a partner pump, they will be switched on in turns when level S2 has been reached.

When sewage continues to flow into the pump sump, the time is saved that is required to reach level S2 and level S1. The pumping time will be corrected based on this. The same correction method can be used for volume detection to compensate in changes in the required pumping time when a partner pump is available.

When one pump cannot supply sufficient pumping capacity to drain away the incoming wastewater, the second pump will be switched on when level S3 is reached. You can determine when the pumps should

be switched off depending on the speed at which the pump sump fills up and the time that is required for it to be pumped and emptied. This can be determined by both calculation and detection of the lowest off switching level.

When one or both pumps have not been in operation for a period of 24 hours, the pump or pumps will start until the lowest off switching level has been detected. The test run will be automatically activated after every 24 hour period when the water level has not demanded a pump start.

3.5.3 Points of special interest

It is very important that the vent hole of the pump housing is opened because the pump continues running until the pump suctions air every eighth cycle.



ATTENTION

When installing a pump with an automatic level regulation, the pump must be at least 20 cm from the wall.



ATTENTION

The pump must be installed in such a way that the inflow of the drain can never reach the sensors for the level regulation.

When a pump with automatic level regulation detects that the water level is still above level S3 after 16 seconds, the pump will stop for a period of 3 seconds will give a coded report for high water. A pump with automatic level regulation must, therefore, only be used in a drain.

4 Transportation

4.1 Transport



WARNING

Lift the pump, if necessary using a hoist and suitable slings. Attach the slings to the hoisting eyes on the packaging, where present.



WARNING

The pump must be hoisted according to the current hoist guidelines. Only qualified personnel are allowed to hoist the pump.

1. Transport the pump in the position as indicated on the pallet or packaging.
2. Make sure the pump is stable.
3. Observe the instructions on the packaging (if present).

4.2 Storage

4.2.1 Storage preparation

1. Spray clean the pump and the impeller in the pump housing well using clean water.
2. Store the pump in a dry and frost-proof location.

4.2.2 Inspection during storage

1. Turn the impeller every three months. This will prevent sticking of the running seals.
2. Have the pump inspected before putting it into operation again after a storage period of 6 months or longer.

5 Installation

5.1 Mechanical installation



WARNING

Remove all cables and hoisting chains from the pump sump. Prevent thus that they can be sucked and damaged by the pump.



WARNING

Never allow the pump to drop from the feeder cable or delivery pipe. Use a chain or a sufficiently strong cable that is attached to the grip of the pump.



WARNING

Do not use the pump in locations where there is freezing danger.

- Take the pump out of the packaging and check for any transportation damage.
- Check whether the delivery is complete based on the included Production Order Combination List. Contact DP-Pumps if the delivery is damaged and/or incomplete.
- Position and assemble the pump system on a suitable surface or suspend the pump using the grip.
- Position the pump on a paved surface when there is mud and sand.
- Check whether the pump impeller can turn freely.
- Make sure that the distance between the bottom and the supply (A) is at least the same as the free passage, see the technical information.
- Assemble, if required, a non-return valve in the delivery pipe to prevent liquid flowing back. The swing check valve must be installed at least 2 m from the pump for the "A" version pump.
- Assemble (if possible) a globe valve on the delivery side.
- Install the highest point of the delivery pipe above the drain pipes of the street (ground level) to make sure that a drain return flow is not possible.

5.2 Electrical installation



WARNING

Only authorised personnel are allowed to make electrical connections to the motor in accordance with local regulations.

Electrical connections:

- Make sure that the motor specifications correspond with the power supply to which the pump motor is connected. Consult "Electrical diagrams" in the annexes for the correct connection diagram.
- Connect the motor using a motor safety switch. The setting must be the same as the motor amperage as listed on the identification label in relation to a direct start (DOL; Direct On Line).
- Connect the pump in accordance with the electrical diagram that can be found in the junction box.
- When the pump is being connected through a frequency transformer, the motor must be provided with a suitable "shielded" cable specially for this situation. The temperature protection in the pump must also be connected to the frequency transformer. Range 30-50 Hz

5.3 Commissioning



WARNING

The pump must not be switched on when it does not contain any liquid.

The direction of rotation of the pump is clockwise seen from the top of the pump (A). The reactive force will cause a shock movement in the opposite direction (B) when started up.

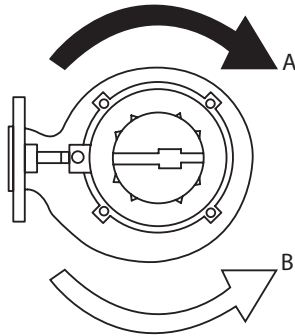

ATTENTION

In case of a 3-phase motor the rotating direction can be changed by exchanging two of the three phase wires.



ATTENTION

You are allowed to reduce the submersible level up to the set point specified in 9.1 Technical specifications when operation is intermittent.



ATTENTION

The pump must be completely submersed when operation is continuous.

Check whether the submersible sewage pump switches on and off at the correct liquid levels when commissioning. Fill the drain up to the on switching level of the pump. Use the liquid to be pumped or clean water.

- 1 Check whether the pump switches on automatically.
- 2 Check whether the pump switches off automatically when reaching the off switching level.
- 3 Check whether liquid is not returned from the delivery pipe in the drain.



ATTENTION

Drill a small hole for venting at the highest point of the pipe system (just before the swing check valve) should air remain enclosed in the pump housing. Provide the hole with a stainless steel nipple to ensure it cannot become rusted up. Remember that liquid can squirt from the drilled hole.



ATTENTION

The DRV6/8 and DRS3 have been fitted with a special bolt that can be removed when there are problems with air staying in the pump housing. The bolt can be found on the other side of the delivery connection under the motor cable inlet.

6 Operation

6.1 Operation

Pump type	operation
xxx-W	pump with earthed plug
xxx-WS	switch on/off the pump automatically through the float switch
xxx-WA	pump automatically on/off through the internal level regulating system
xxx-S	MANUAL - switch on the pump manually 0 - pump off Auto - pump automatically on/off through the float switch
xxx-	pump with free cable end
xxx-	pump with junction box, will switch on/off automatically through the internal level regulating system

7 Maintenance

7.1 Maintenance



WARNING
Disconnect the power supply to the system before performing maintenance work, and protect this disconnection.



WARNING
Remember that the motor can be hot when it has just been switched off.



WARNING
Clean the pump with clean water before carrying out maintenance work.



WARNING
Ensure that the guide clamp does not become jammed on the guide bars if a tackle is being used to remove the pump from the drain.

Regular maintenance will promote the permanent good operation of the installation. DP-Pumps has its own maintenance department with specialised engineers. A draft maintenance contract is available upon request.

7.1.1 Maintenance schedule

The pump must be checked every 4000 operational hours or at least once a year. We recommend carrying out an overhaul every 5 years.

The maintenance interval should be adjusted when operational conditions are heavier.

The bearings of the pump have been lubricated for life and, therefore, do not require maintenance.

7.1.2 Oil chamber check



ATTENTION
All pumps have a closed, maintenance-free system. Only the pumps of the DRK type or in the HT or E version have a checking option.

Check the oil chamber for any leaks of the seals.

- 1 Remove the inspection plug of the pump housing.
- 2 Position the pump in a horizontal position with the inspection opening downwards.

Any liquid that may be present in the pump housing can now flow out through the opening. Check the composition of the liquid to discover any leaks.

Liquid	Cause
Clear oil	No leaks.
Lightly coloured oil	A small quantity of moisture is allowed.
Water/oil	Not allowed; the seal or pump is leaking ¹
Overpressure	Not allowed; seal or motor is leaking ¹

1. Contact the supplier.

7.1.3 Checking and cleaning the shredder device (DRS)

Disassemble the shredder device and suction cover and clean and perform an inspection. Next, install the shredder device according to:

- 1 Position the impeller with the cutter head on the pump shaft.
- 2 Secure the impeller.
- 3 Turn back the adjusting screws of the suction cover up to the flange to ensure they no longer protrude.
- 4 Install the suction cover in the pump housing.
- 5 Press the suction cover until the flange is on the impeller everywhere.
- 6 Tighten the adjusting screws until the impeller is just turning freely (gap = 0.3mm +/- 0.1mm).
- 7 Tighten the fastening bolts tightly.



ATTENTION

Again check whether the impeller can turn freely.

7.2 Taking out of operation for a long interval

Turn the impeller every three months. This will prevent seals from sticking.

Protect the pump against freezing if there is a risk of frost. Proceed as follows:

1. Close all globe valves.
2. Remove the pump from the drain.
3. Make sure the pump is cleaned correctly by spraying with a powerful water jet.
4. Store the pump in a dry and frost-proof location.

8 Failures

8.1 Failure table



WARNING

Take the general safety measures for the installation, maintenance and repair into consideration.

Problem	Possible cause	Possible solution	Checkpoints
The pump will not start	No voltage on the terminal clamps	Check the power supply	<ul style="list-style-type: none"> • Circuit • Main switch • Hand-0-Aut switch • Fuses
		Check the motor safety relay	<ul style="list-style-type: none"> • Earth leakage switch • Protective relay • Motor temperature • Water feeler (option)
		Check the start signal	<ul style="list-style-type: none"> • Medium level • Level switching • Start-stop change • Switch box
	Motor failures	Check the motor	<ul style="list-style-type: none"> • Insulation test • Phase resistance
The pump does not stop	No stop signal	Check level switching	<ul style="list-style-type: none"> • Level switching • Switch box
	Air in the pump housing	Temporarily remove the pump from the coupling	Pump switching level
The pump starts and stops quickly after each other	Incorrect start/stop signal	Check the level switches	<ul style="list-style-type: none"> • Level switching • Adjusting switches
	Power supply is unstable	Check the power supply	<ul style="list-style-type: none"> • Circuit • Undervoltage • 3-phase available? • Adjustment of the motor protection • Fuses
Pump current is too high	Current failure	Check the power supply	<ul style="list-style-type: none"> • Fuses • Undervoltage
	Pump failure	Check the pump	<ul style="list-style-type: none"> • Impeller blockage • Viscosity of the medium
	The direction of rotation is incorrect	Reverse the direction of rotation	
	The capacity is too high	Increase the counterpressure	

Problem	Possible cause	Possible solution	Checkpoints
Too little or no pump capacity	Blockage or an air bubble in the pump	Check the delivery pipe and the pump	<ul style="list-style-type: none"> • Delivery pipe (blockage) • Globe valve (half or fully closed) • Inclusion of air • Blockage (impeller) • Check level switching
	Incorrect direction of rotation	Reverse the direction of rotation	Direction of rotation
	Pump failure	Check the pump	<ul style="list-style-type: none"> • Coupling (leaking) • Impeller (has come loose or is damaged) • Impeller or pump housing (blockage) • Bearings damaged
	Power supply is unstable	Check the power supply	<ul style="list-style-type: none"> • Switch box • Fuses • Undervoltage
High water alarm	Too little pump capacity	Check the delivery pipe	<ul style="list-style-type: none"> • Delivery pipe (blockage) • Globe valve (half or fully closed) • Inclusion of air
	Pump failure	Check the pump	<ul style="list-style-type: none"> • Impeller or pump housing (blockage) • Impeller (has come loose or is damaged) • Bearings damaged
	Current failure	Check the power supply	<ul style="list-style-type: none"> • Fuses • Undervoltage
	Motor failures	Check the motor	<ul style="list-style-type: none"> • Junction box • Insulation test

9 Annexes

9.1 Technical specifications

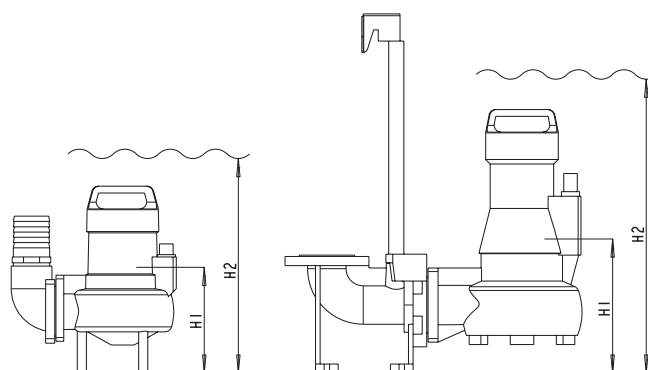

pump type	P [kW]	Inom [A]	Umotor [V]	n [min ⁻¹]	tempera- ture protec- tion	cable type [n x mm ²]	H1 [mm]	Connec- tion [DN]	Free pas- sage [mm]	Mass [kg]
DRV66-2 100	0.55	2.3	3*400	2850	naw	4*1	160	50	45	22
DRV66-2A 100	0.55	2.3	3*400	2850	naw	4*1	65	50	45	22
DRV66-2W(S) 100	0.55	5	1*230	2850	clixon	3*1	160	50	45	22
DRV66-2WA 100	0.55	5	1*230	2850	clixon	3*1	65	50	45	22
DRV68-2 110	0.75	2.8	3*400	2850	naw	4*1	160	50	45	22
DRV68-2A 110	0.75	2.8	3*400	2850	naw	4*1	65	50	45	22
DRV68-2W(S) 110	0.75	6	1*230	2850	clixon	3*1	160	50	45	22
DRV68-2WA 110	0.75	6	1*230	2850	clixon	3*1	65	50	45	22
DRV611-2 120	1.1	3	3*400	2850	naw	4*1	160	50	43	22
DRV611-2A 120	1.1	3	3*400	2850	naw	4*1	65	50	43	22
DRV611-2W(S) 120	1.1	8.2	1*230	2850	clixon	3*1	160	50	43	22
DRV611-2WA 120	1.1	8.2	1*230	2850	clixon	3*1	65	50	43	22
DRV611-2W(S) 130	1.1	8.2	1*230	2850	clixon	3*1	160	50	41	22
DRV611-2WA 130	1.1	8.2	1*230	2850	clixon	3*1	65	50	41	22
DRV615-2 130	1.5	3.5	3*400	2850	naw	4*1	160	50	41	22
DRV615-2A 130	1.5	3.5	3*400	2850	naw	4*1	65	50	41	22
DRV88-2 110	0.75	2.8	3*400	2850	naw	4*1	170	65	60	25
DRV88-2A 110	0.75	2.8	3*400	2850	naw	4*1	70	65	60	25
DRV88-2W(S) 110	0.75	6	1*230	2850	clixon	3*1	170	65	60	25
DRV88-2WA 110	0.75	6	1*230	2850	clixon	3*1	70	65	60	25
DRV811-2 120	1.1	3	3*400	2850	naw	4*1	170	65	58	25
DRV811-2A 120	1.1	3	3*400	2850	naw	4*1	70	65	58	25
DRV811-2W(S) 120	1.1	8.2	1*230	2850	clixon	3*1	170	65	58	25
DRV811-2WA 120	1.1	8.2	1*230	2850	clixon	3*1	70	65	58	25

pump type	P [kW]	Inom [A]	Umotor [V]	n [min ⁻¹]	tempera- ture protec- tion	cable type [n x mm ²]	H1 [mm]	Convec- tion [DN]	Free pas- sage [mm]	Mass [kg]
DRV811-2W(S) 130	1.1	8.2	1*230	2850	clixon	3*1	170	65	56	25
DRV811-2WA 130	1.1	8.2	1*230	2850	clixon	3*1	70	65	56	25
DRV815-2 130	1.5	3.5	3*400	2850	naw	4*1	170	65	56	25
DRV815-2A 130	1.5	3.5	3*400	2850	naw	4*1	70	65	56	25
DRV913-2 90(107)	1.3	3.56	3*400	2850	bi-metal	7*1.5	207	50	40	41
DRV919-2 120	1.9	4.5	3*400	2850	bi-metal	7*1.5	207	50	40	42
DRV923-2 130	2.3	5.1	3*400	2850	bi-metal	7*1.5	207	50	40	42
DRV1131-2 130(140)	3.1	7	3*400	2850	bi-metal	7*1.5	203	50	40	52
DRV1142-2 150	4.2	8.8	3*400	2850	bi-metal	7*1.5	203	50	40	53
DRV128-4 112 (125/135/145/155)	0.8	2.75	3*400	1450	bi-metal	7*1.5	253	65	65	49
DRV1213-4 165(175)	1.3	3.54	3*400	1450	bi-metal	7*1.5	253	65	65	50
DRV1218-4 185(195)	1.8	4.25	3*400	1450	bi-metal	7*1.5	253	65	65	51
DRV1331-2 120(128)	3.1	7	3*400	2850	bi-metal	7*1.5	248	65	65	58
DRV1331-2 136	3.1	7	3*400	2850	bi-metal	7*1.5	248	65	65	59
DRV1342-2 146	4.2	8.8	3*400	2850	bi-metal	7*1.5	248	65	65	59
DRV1342-2 152	4.2	8.8	3*400	2850	bi-metal	7*1.5	248	65	65	60
DRV2419-4 120 (135/150)	1.9	5.87	3*400	1450	bi-metal	7*1.5	249	80	76	63
DRV2426-4 165	2.6	6.5	3*400	1450	bi-metal	7*1.5	249	80	76	64
DRV2437-4 180(195)	3.7	8.4	3*400	1450	bi-metal	7*1.5	249	80	76	65
DRV2719-4 120(135)	1.9	5.87	3*400	1450	bi-metal	7*1.5	277	100	100	64
DRV2726-4 150	2.6	6.5	3*400	1450	bi-metal	7*1.5	277	100	100	64
DRV2737-4 165	3.7	8.4	3*400	1450	bi-metal	7*1.5	277	100	100	65
DRV2737-4 180	3.7	8.4	3*400	1450	bi-metal	7*1.5	277	100	100	66
DRV2737-4 195	3.7	8.4	3*400	1450	bi-metal	7*1.5	277	100	100	67
DRK2385-2 182	8.5	16.7	400/692	2905	bi-metal	12*1.5	320	80	42	151
DRK2385-2 196	8.5	16.7	400/692	2905	bi-metal	12*1.5	320	80	42	151
DRK4155-4 202(220)	5.5	12.1	400/692	1430	bi-metal	12*1.5	380	100	90	141
DRK4175-4 245	7.5	15.8	400/692	1440	bi-metal	12*1.5	380	100	90	155
DRK87118-4 254	11.8	23.5	400/692	1465	bi-metal	12*1.5	455	150	110	146
DRK87160-4 275	16	33	400/692	1465	bi-metal	7*4+5*1.5	455	150	110	256
DRK87210-4 295	21	40.5	400/692	1435	bi-metal	7*4+5*1.5	455	150	110	325
DRK87270-4 305	27	55	400/692	1455	bi-metal	7*6+5*1.5	455	150	110	343
DRK107118-4 235(250)	11.8	23.5	400/692	1465	bi-metal	12*1.5	455	150	76	146
DRK107160-4 265	16	33	400/692	1465	bi-metal	7*4+5*1.5	455	150	76	256
DRK107210-4 280	21	40.5	400/692	1435	bi-metal	7*4+5*1.5	455	150	76	325
DRK107270-4 295	27	55	400/692	1455	bi-metal	7*6+5*1.5	455	150	76	343
DRK145130-6 319(351)	13	27.5	400/692	965	bi-metal	7*4+5*1.5	750	200	121	480
DRK145180-6 373	18	35.5	400/692	955	bi-metal	7*4+5*1.5	750	200	121	480
DRK145240-6 400	24	47	400/692	960	bi-metal	7*6+5*1.5	750	200	121	505
DRK178130-6 300	13	27.5	400/692	965	bi-metal	7*4+5*1.5	600	250	85	555
DRK178180-6 318	18	35.5	400/692	955	bi-metal	7*4+5*1.5	600	250	85	555
DRK178240-6 340	24	47	400/692	960	bi-metal	7*6+5*1.5	600	250	85	580
DRK178300-6 370	30	64	400/692	975	bi-metal	2*4*6+ 12*1.5	600	250	85	710
DRK250100-8 332(355)	10	22.5	400/692	715	bi-metal	12*1.5	750	300	135	735

pump type	P [kW]	Inom [A]	Umotor [V]	n [min ⁻¹]	tempera- ture protec- tion	cable type [n x mm ²]	H1 [mm]	Convec- tion [DN]	Free pas- sage [mm]	Mass [kg]
DRK250100-8 332	10	22.5	400/692	715	bi-metal	12*1.5	750	300	135	735
DRK250200-8 390	20	44	400/692	705	bi-metal	7*6+5*1.5	750	300	135	775
DRK250280-8 408	28	60	400/692	730	bi-metal	2*4*4+ 12*1.5	750	300	135	900
DRS311-2W(S) 145	1.1	8.2	1*230	2850	clixon	4*1	160	50	7	26
DRS311-2WA 145	1.1	8.2	1*230	2850	clixon	4*1	84	50	7	26
DRS315-2 145	1.5	3.5	3*400	2850	naw	4*1	160	50	7	24
DRS315-2A 145	1.5	3.5	3*400	2850	naw	4*1	84	50	7	24
DRS413-2 120(140)	1.3	3.56	3*400	2850	bi-metal	7*1.5	207	50	6	39
DRS419-2 160	1.9	4.5	3*400	2850	bi-metal	7*1.5	207	50	6	39
DRS631-2 175	3.1	7	3*400	2850	bi-metal	7*1.5	203	50	6	54
DRS642-2 190	4.2	8.8	3*400	2850	bi-metal	7*1.5	203	50	6	54
DRSK 2119-4 154	1.9	5.9	3*400	1450	bi-metal	7*1.5	602	80	65	74
DRSK 2119-4 168	1.9	5.9	3*400	1450	bi-metal	7*1.5	602	80	65	74
DRSK 2119-4 180	1.9	5.9	3*400	1450	bi-metal	7*1.5	602	80	65	74
DRSK 2119-4 190	1.9	5.9	3*400	1450	bi-metal	7*1.5	602	80	65	75
DRSK 3126-4 195	2.6	6.5	3*400	1450	bi-metal	7*1.5	628	100	76	79
DRSK 3137-4 209	3.7	8.4	3*400	1450	bi-metal	7*1.5	628	100	76	79
DRSK 3137-4 220	3.7	8.4	3*400	1450	bi-metal	7*1.5	628	100	76	80

9.2 Electrical connections



ATTENTION

The bi-metal switch (connection 21-22) of the pump is suitable for switching 250 V AC at 2 A. Do not connect connection 20; do shield it.

Table 4: Cable coding

		DRV 6/8 DRS 3	DRV 9/11/12/13/ 24/27 DRS 4/6 DRSK 21 / 31	DRK (n = 12)	DRK (n = 1x7 + 1x5)
L1	U1	black	1	1	1
L2	V1	blue	2	2	2
L3	W1	brown	3	3	3
Dummy connection	20		4		
Bi-metal	21		5	7	1
	22		6	8	2
Earthing	PE	green/yellow	green/yellow	green/yellow	green/yellow
L2' Δ	U2			4	4
L3' Δ	V2			5	5
L1' Δ	W2			6	6
PTC ¹	10			9	3
	11			10	4
Humidity sensor ¹	9			11	5

1. PTC and humidity sensor depends on the type of motor.

9.3 Declaration of conformity (IIA)

factory certificate (2.1) according to NEN-EN-10204

Undersigned:
DP-Pumps
Kalkovenweg 13
2401 LJ Alphen aan den Rijn, The Netherlands
Tel: (+31)(0)-172-48 83 21
Fax: (+31)(0)-172-46 89 40

Declares as manufacturer entirely on his own responsibility, that the products:

Product: Submersible sewage pumps
Type: DRV / DRK / DRS / DRSK

to which this declaration refers, is in accordance with the following standards:

EN-809, EN-12100-1
EN-61000-6-1/3
EN-61000-3-2, EN-1010 and EN-IEC 60204-1

according to the stipulations of

Machinery Directive 98/37/EC
EMC Directive 89/336/EEC
Low Voltage Directive 73/23/EEC

If the pump is used as a standalone installation, it is subject to this declaration of conformity.

If the pump is built in an appliance or is assembled together with other equipment in certain installations, then it should not be put into operation until a declaration has been given with respect to the appliance concerned that it complies with the directives listed above.



Alphen aan den Rijn,
18-05-2006

Responsible person:
W. Ouwehand, technical director



dp pumps

dp pumps
P.O. Box 28
2400 AA Alphen aan den Rijn
The Netherlands

t +31 172 48 83 25
f +31 172 46 89 30

dp@dp-pumps.com
www.dp-pumps.com

03-2007

BE00000305

